



PSEN cs6.1p

PILZ
THE SPIRIT OF SAFETY

- ▶ PSEN sensor technology

This document is the original document.

All rights to this documentation are reserved by Pilz GmbH & Co. KG. Copies may be made for the user's internal purposes. Suggestions and comments for improving this documentation will be gratefully received.

Source code from third-party manufacturers or open source software has been used for some components. The relevant licence information is available on the Internet on the Pilz homepage.

Pilz®, PIT®, PMI®, PNOZ®, Primo®, PSEN®, PSS®, PVIS®, SafetyBUS p®, SafetyEYE®, SafetyNET p®, the spirit of safety® are registered and protected trademarks of Pilz GmbH & Co. KG in some countries.



SD means Secure Digital

Introduction	5
Validity of documentation	5
Using the documentation	5
Definition of symbols	5
Safety	6
Intended use	6
Safety regulations	7
Safety assessment	7
Additional documents that apply	7
Use of qualified personnel	7
Warranty and liability	8
Disposal	8
For your safety	8
Unit features	8
Function description	9
Basic function	9
Block diagram	10
Safety Device Diagnostics	10
Operating distances	11
Lateral and vertical offset	13
Wiring	19
Important information	19
Connection to evaluation devices	21
Single connection	21
Series connection	23
Connection to Pilz evaluation devices	26
Teaching in the actuator	27
Installation	28
General	28
Safety switch	30
Actuator 6.1	30
Actuator 6.1 low profile	30
Align safety switch and actuator	33
Use in operating heights higher than 2000 m above sea level	34
Adjustment	34
Operation	35
Normal mode	35
Error display	36

Dimensions in mm	37
Technical details safety switch	38
Technical details actuator	42
Classification according to ZVEI, CB24I	45
Safety characteristic data	45
Supplementary data	46
Radio approval.....	46
Order reference	46
Safety switch.....	46
Actuator	47
Complete systems	47
Accessories	47
EC declaration of conformity	49

Introduction

Validity of documentation

This documentation is valid for the product PSEN cs6.1p from Version 2.0.

This operating manual explains the function and operation, describes the installation and provides guidelines on how to connect the product.

Using the documentation

This document is intended for instruction. Only install and commission the product if you have read and understood this document. The document should be retained for future reference.

Definition of symbols

Information that is particularly important is identified as follows:



DANGER!

This warning must be heeded! It warns of a hazardous situation that poses an immediate threat of serious injury and death and indicates preventive measures that can be taken.



WARNING!

This warning must be heeded! It warns of a hazardous situation that could lead to serious injury and death and indicates preventive measures that can be taken.



CAUTION!

This refers to a hazard that can lead to a less serious or minor injury plus material damage, and also provides information on preventive measures that can be taken.



NOTICE

This describes a situation in which the product or devices could be damaged and also provides information on preventive measures that can be taken. It also highlights areas within the text that are of particular importance.

**INFORMATION**

This gives advice on applications and provides information on special features.

Safety**Intended use**

The safety functions of the safety switch are:

- ▶ Safe shutdown of safety outputs when the actuator is removed beyond the assured release distance s_{ar} or when the actuator is not detected
- ▶ Remain shut down safely after the actuator has been removed

The safety switch meets the requirements in accordance with:

- ▶ EN 60947-5-3: PDDB with one of the approved actuators
- ▶ EN 62061: SIL CL 3
- ▶ EN ISO 13849-1: PL e (Cat. 4)
- ▶ EN ISO 14119: Coding level High, type 4

The safety switch may only be used with one of the approved actuators.

The safety level PL e (Cat. 4)/SIL CL 3 is only achieved if

- ▶ the safety outputs use 2-channel processing.

The following is deemed improper use in particular

- ▶ Any component, technical or electrical modification to the product,
- ▶ Use of the product outside the areas described in this manual,
- ▶ Use of the product outside the technical details (see [Technical details](#)  38]).

**NOTICE****EMC-compliant electrical installation**

The product is designed for use in an industrial environment. The product may cause interference if installed in other environments. If installed in other environments, measures should be taken to comply with the applicable standards and directives for the respective installation site with regard to interference.

Approved actuators:

- ▶ PSEN cs6.1
- ▶ PSEN cs6.1 low profile glue
- ▶ PSEN cs6.1 low profile screw

Safety regulations

Safety assessment

Before using a device it is necessary to perform a safety assessment in accordance with the Machinery Directive.

Functional safety is guaranteed for the product as a single component. However, this does not guarantee the functional safety of the overall plant/machine. In order to achieve the required safety level for the overall plant/machine, define the safety requirements for the plant/machine and then define how these must be implemented from a technical and organisational standpoint.

Additional documents that apply

Please read and take note of the following documents.

Only for use of the Safety Device Diagnostics (SDD):

- ▶ Operating manual for the fieldbus module, for example SDD ES ETH or SDD ES PROFIBUS
- ▶ System description "Safety Device Diagnostics"

For the use of passive junctions:

- ▶ Operating manual of a passive junction, for example:
 - PSEN ix2 F4 code
 - PSEN ix2 F8 code
 - PDP67 F 4 code
 - PSEN Y junction

You will need to be conversant with the information in these documents in order to fully understand this operating manual.

Use of qualified personnel

The products may only be assembled, installed, programmed, commissioned, operated, maintained and decommissioned by competent persons.

A competent person is a qualified and knowledgeable person who, because of their training, experience and current professional activity, has the specialist knowledge required. To be able to inspect, assess and operate devices, systems and machines, the person has to be informed of the state of the art and the applicable national, European and international laws, directives and standards.

It is the company's responsibility only to employ personnel who

- ▶ Are familiar with the basic regulations concerning health and safety / accident prevention,
- ▶ Have read and understood the information provided in the section entitled Safety
- ▶ Have a good knowledge of the generic and specialist standards applicable to the specific application.

Warranty and liability

All claims to warranty and liability will be rendered invalid if

- ▶ The product was used contrary to the purpose for which it is intended,
- ▶ Damage can be attributed to not having followed the guidelines in the manual,
- ▶ Operating personnel are not suitably qualified,
- ▶ Any type of modification has been made (e.g. exchanging components on the PCB boards, soldering work etc.).

Disposal

- ▶ In safety-related applications, please comply with the mission time T_M in the safety-related characteristic data.
- ▶ When decommissioning, please comply with local regulations regarding the disposal of electronic devices (e.g. Electrical and Electronic Equipment Act).

For your safety



WARNING!

Loss of safety function due to manipulation of the interlocking device

Manipulation of the interlocking device may lead to serious injury and death.

- You should prevent any possibility of the interlocking device being manipulated through the use of a spare actuator.
- Keep the substitute actuator in a safe place and protect it from unauthorised access.
- If spare actuators are used, these must be installed as described in [Installation](#) [ 28].
- If the original actuators are replaced with substitute actuators, the original actuators must be destroyed before disposal.

- ▶ Do not remove the connector's protective cap until you are just about to connect the unit. This will prevent potential contamination.

Unit features

- ▶ Transponder technology for presence detection
- ▶ Pilz coding type: fully coded
- ▶ Dual-channel operation
- ▶ 2 safety inputs for series connection of multiple safety switches
- ▶ 2 safety outputs
- ▶ Safety Device Diagnostics (SDD)
 - Safety Device Diagnostics can be used to poll sensor information, to perform actions and to read configuration parameters
 - Manipulation protection in accordance with ISO 14119 is possible by verifying the short name of the actuator through the controller via SDD communication

- ▶ Diagnostic input for Y1 for Safety Device Diagnostics (SDD)
- ▶ Signal output/diagnostic output Y32 for Safety Device Diagnostics
- ▶ LED display for:
 - State of actuator detection
 - State of the inputs
 - Supply voltage/fault
- ▶ 4 actuation directions, each with 3 approach directions (see [Explanation of markings](#) [ 11])
 - Square marking for normal operating distance
 - Triangle marking for short operating distance
 - 2 semicircle markings for a lateral approach. Please note the Lateral and vertical offset with the lateral approach to the semicircle marking.

The guaranteed safe operating distances for the specified selections only apply when the actuator approaches the switch vertically. With the other approach directions, the operating distances may sometimes be considerably larger (particularly when approaching the semicircle).

Function description

Basic function

The safety outputs may have a high or low signal, depending on the position of the actuator and the signal status of the safety inputs.

Electrical states of the safety inputs and outputs (when switch is ready for operation: DEVICE LED is green):

Actuator in the re- sponse range	Safety input S11	Safety input S21	Safety out- put 12	Safety out- put 22	Signal out- put Y32 (without use of the SDD)
Yes	High	High	High	High	High
Yes	Low	Low	Low	Low	High
No	x	x	Low	Low	Low
Yes	High	Low	High	Low	High
Yes	Low	High	Low	High	High

x: High or low signal

Feasibility monitoring for safety inputs S11 and S21

- ▶ If one safety input switches from high to low, while the other safety input remains high, an unequal status is displayed: **Input LED has quick yellow flashes and Device LED flashes red**
- ▶ If this safety input switches back from low to high, while the other safety input remains high, a feasibility error is displayed and a partial operation lock is triggered: **Input LED flashes yellow and Device LED flashes red**

A switch to a high signal will only lead to normal switch operation if both inputs had a low signal. From this moment on, the switch to high may occur (partial operation lock see [Error display](#) [36]).

► Diagnostic input Y1

If a fieldbus module of the SDD is used, the diagnostic input Y1 is automatically activated and data is read.

If no fieldbus module of the SDD is used, the diagnostic input Y1 is not used.

► Signal output/diagnostic output Y32

The status of the actuator is output. If a fieldbus module of the SDD is used, the signal output/diagnostic output for the writing of data is activated.

Block diagram

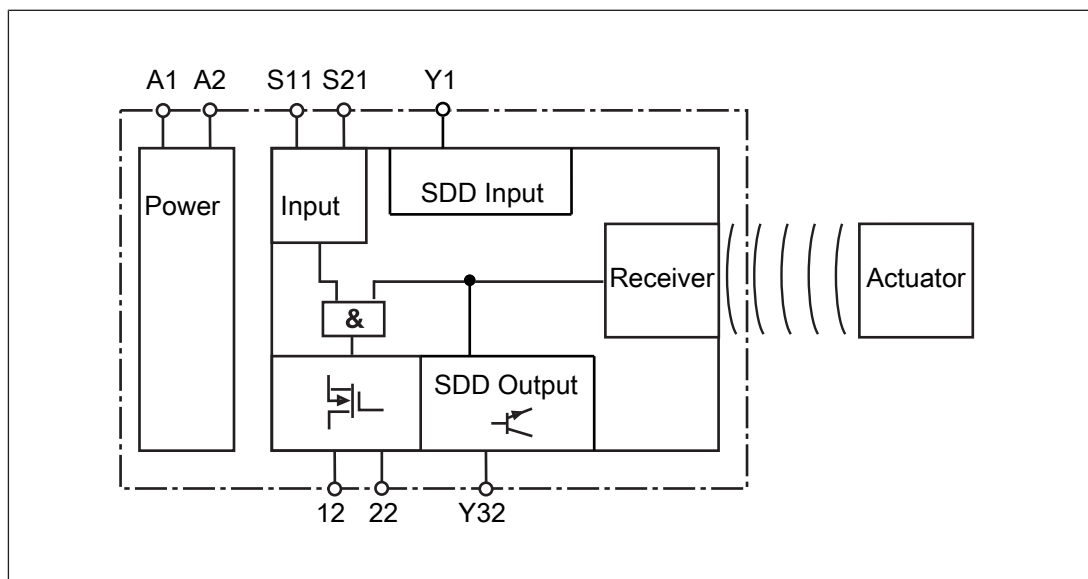

Safety Device Diagnostics

Safety Device Diagnostics is an option that can be selected independently of the safety-related wiring.

When using the Safety Device Diagnostics, up to 16 sensors connected in series can be connected as a subscriber to a fieldbus module.

The communication of the sensors with the fieldbus module is automatically built up again with each new supply of the supply voltage. As a result, a sensor can be exchanged, e.g. when servicing, without the need for special measures.

An exchange can be detected via the fieldbus module e.g. through the serial number.

► With Safety Device Diagnostics there are the following diagnostic options for the fieldbus module:

- Poll information of the sensors (examples: what sensor in the series has switched, at what point could there be an open circuit in the series connection)
- Read configuration parameters of the sensor (examples: Number of teach-in processes remaining, serial number of the sensor)
- Perform actions (example: poll updated actuator name)

The results of the sensor diagnostics can be checked already during the installation phase via the display in the fieldbus module, without the need to connect the fieldbus module to the network.

► With Safety Device Diagnostics there are the following diagnostic options for the fieldbus module for simple wiring:

- Information is passed on via the fieldbus module directly to the network
- Mappings of the signal outputs to the sensor are automated by the SDD.

This prevents wiring errors and an expansion or reduction of the sensors is possible without the need to change existing wiring.

- Wiring in accordance with IP20: Rapid installation in the control cabinet is enabled.
- Wiring in accordance with IP67: Various passive junctions can be used (see [Order references for accessories \[47\]](#)) to connect several sensors with only one cable from the field in the control cabinet.

Further information on Safety Device Diagnostics can be found in [Additional documents that apply \[7\]](#).

Operating distances

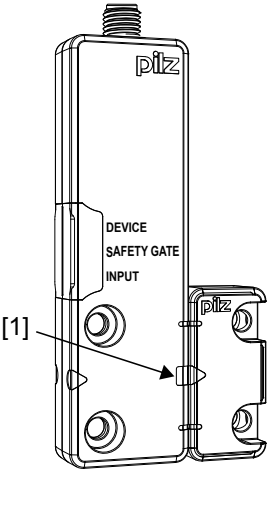
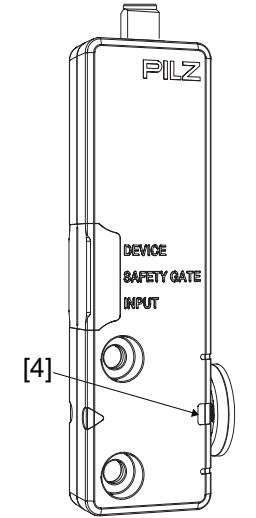
Actuator PSEN cs6.1	Actuator PSEN cs6.1 low profile glue or PSEN cs6.1 low pro- file screw	
		<p>[1] Actuator PSEN cs6.1 aligned to the square marking on the switch</p> <p>S_{ao} Assured operating distance: 8 mm S_{ar} Assured release distance: 20 mm S_o Typical operating distance: 11 mm S_r Typical release distance: 14 mm</p> <p>[4] Actuator PSEN cs6.1 low profile glue or PSEN cs6.1 low profile screw aligned to the square marking on the switch</p> <p>S_{ao} Assured operating distance: 5 mm S_{ar} Assured release distance: 20 mm S_o Typical operating distance: 10 mm S_r Typical release distance: 12 mm</p>

		<p>[2] Actuator PSEN cs6.1 aligned to the triangle marking on the switch</p> <p>S_{ao} Assured operating distance: 4 mm S_{ar} Assured release distance: 12 mm S_o Typical operating distance: 5 mm S_r Typical release distance: 8 mm</p> <p>The alignment of the actuators PSEN cs6.1 low profile glue or PSEN cs6.1 low profile screw to the triangle marking is not provided for</p>
		<p>[3] Actuator PSEN cs6.1 aligned to the semicircle marking on the switch</p> <p>S_{ao} Assured operating distance: 6 mm S_{ar} Assured release distance: 19 mm S_o Typical operating distance: 9 mm S_r Typical release distance: 11 mm</p> <p>[6] Actuator PSEN cs6.1 low profile glue or PSEN cs6.1 low profile screw aligned to the semicircle marking on the switch</p> <p>S_{ao} Assured operating distance: 5 mm S_{ar} Assured release distance: 17 mm S_o Typical operating distance: 8 mm S_r Typical release distance: 10 mm</p>

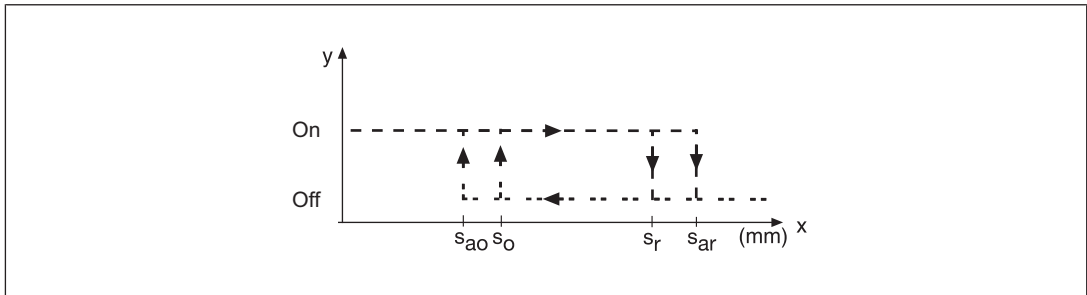

The switching distances of the actuators PSEN cs6.1 low profile glue and PSEN cs6.1 low profile screw were determined under the following conditions:

- ▶ Assured operating distance S_{ao} and assured release distance S_{ar}
 - Measurement over the entire temperature range
 - Installed on various base materials
 - Taking into account product tolerances
- ▶ Typical operating distance S_o and typical release distance S_r
 - Measured at room temperature
 - Installed on plastic

Lateral and vertical offset

Lateral offset when aligning to the triangle or square marking

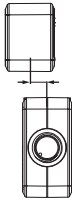
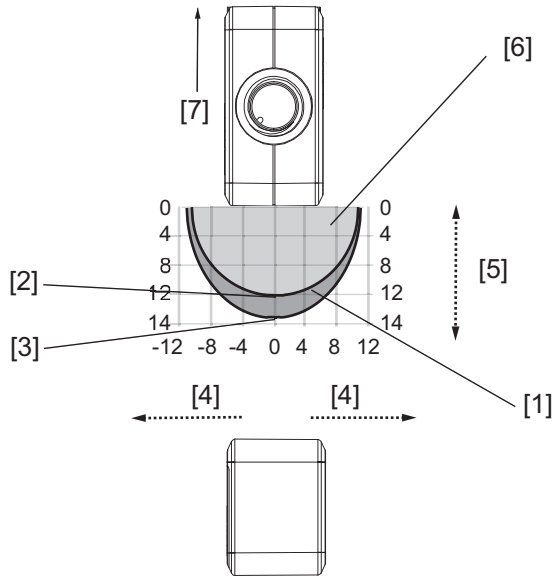
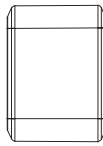
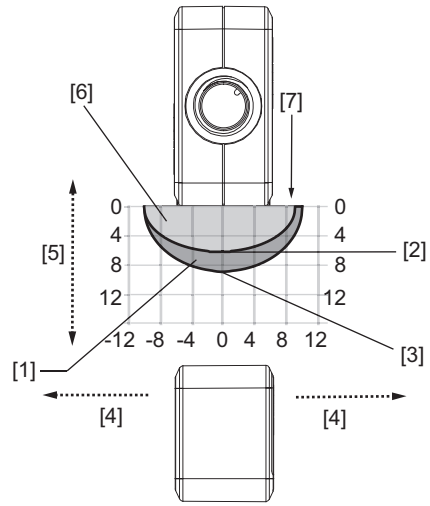
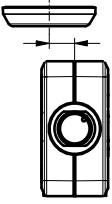
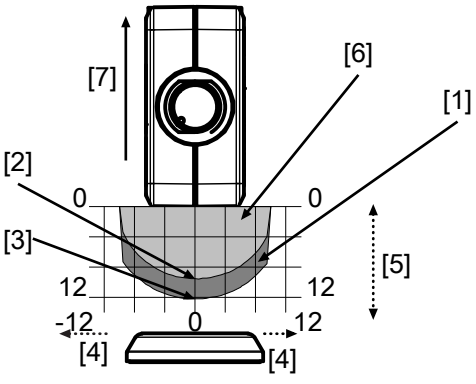
Alignment 1: Actuator PSEN cs6.1 aligned to the square marking on the switch		Alignment 2: Actuator PSEN cs6.1 aligned to the triangle marking on the switch	
			
Alignment 1: Actuator PSEN cs6.1 low profile glue or PSEN cs6.1 low profile screw aligned to the square marking on the switch		Alignment 2: Actuator PSEN cs6.1 low profile glue or PSEN cs6.1 low profile screw aligned to the triangle marking on the switch	
		<p>Actuator PSEN cs6.1 low profile glue or PSEN cs6.1 low profile screw to triangle marking is not suitable because the operating distances are too low.</p>	

Legend

- [1] Hysteresis
- [2] Typical operating distance S_o
- [3] Typical release distance S_r
- [4] Offset in mm
- [5] Operating distance in mm
- [6] Response range
- [7] Status of LED

Lateral offset when aligning to the semicircle marking

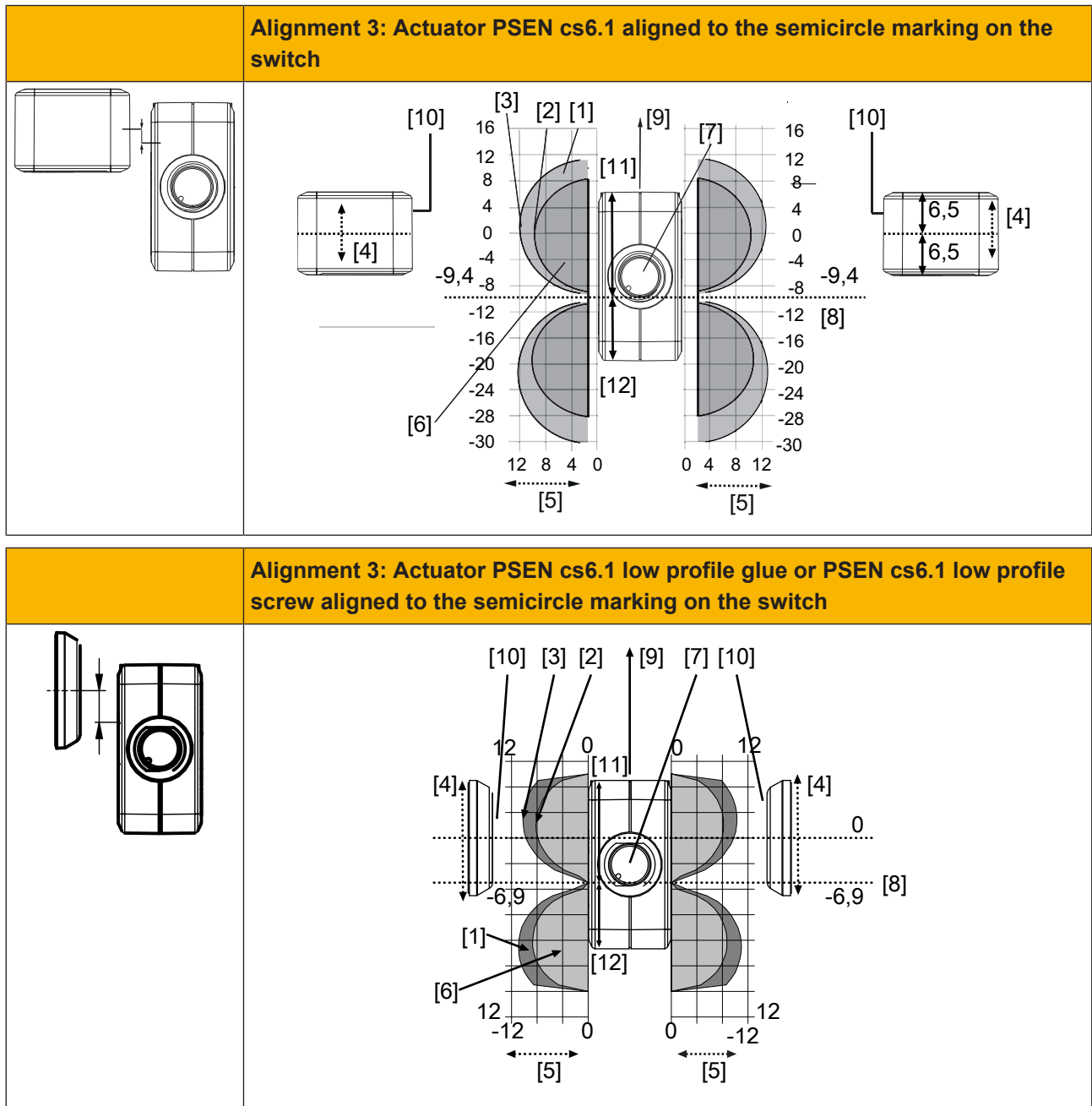

Legend

- [1] Hysteresis
- [2] Typical operating distance S_o
- [3] Typical release distance S_r
- [4] Offset in mm (distance of the middle of the actuator to the zero line in the grid)
- [5] Operating distance in mm
- [6] Response range
- [7] Connector on the safety switch
- [8] Limit of response range, position of gate hinge
- [9] Status of LED
- [10] Sensing face of the actuator, labelled with Pilz logo

[11] Distance from the front edge of the safety switch to the limit of the response range (position of the gate end stop) = 15.9 mm

[12] Distance from the rear edge of the safety switch to the limit of the response range (position of the gate end stop) = 10.5 mm

Vertical offset when aligning to the triangle or square marking

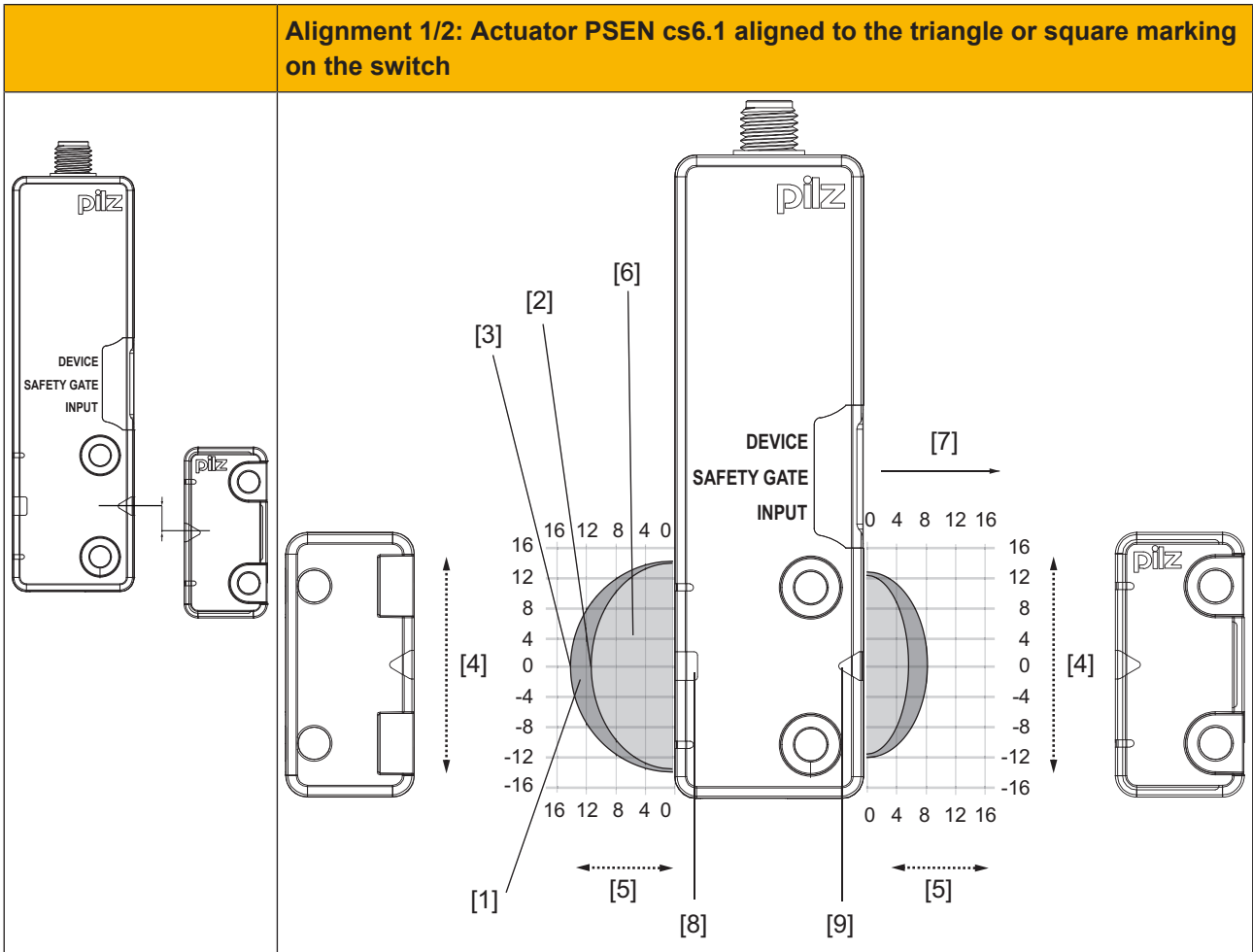

Alignment 1/2: Actuator PSEN cs6.1 low profile glue or PSEN cs6.1 low profile screw aligned to the square marking on the switch

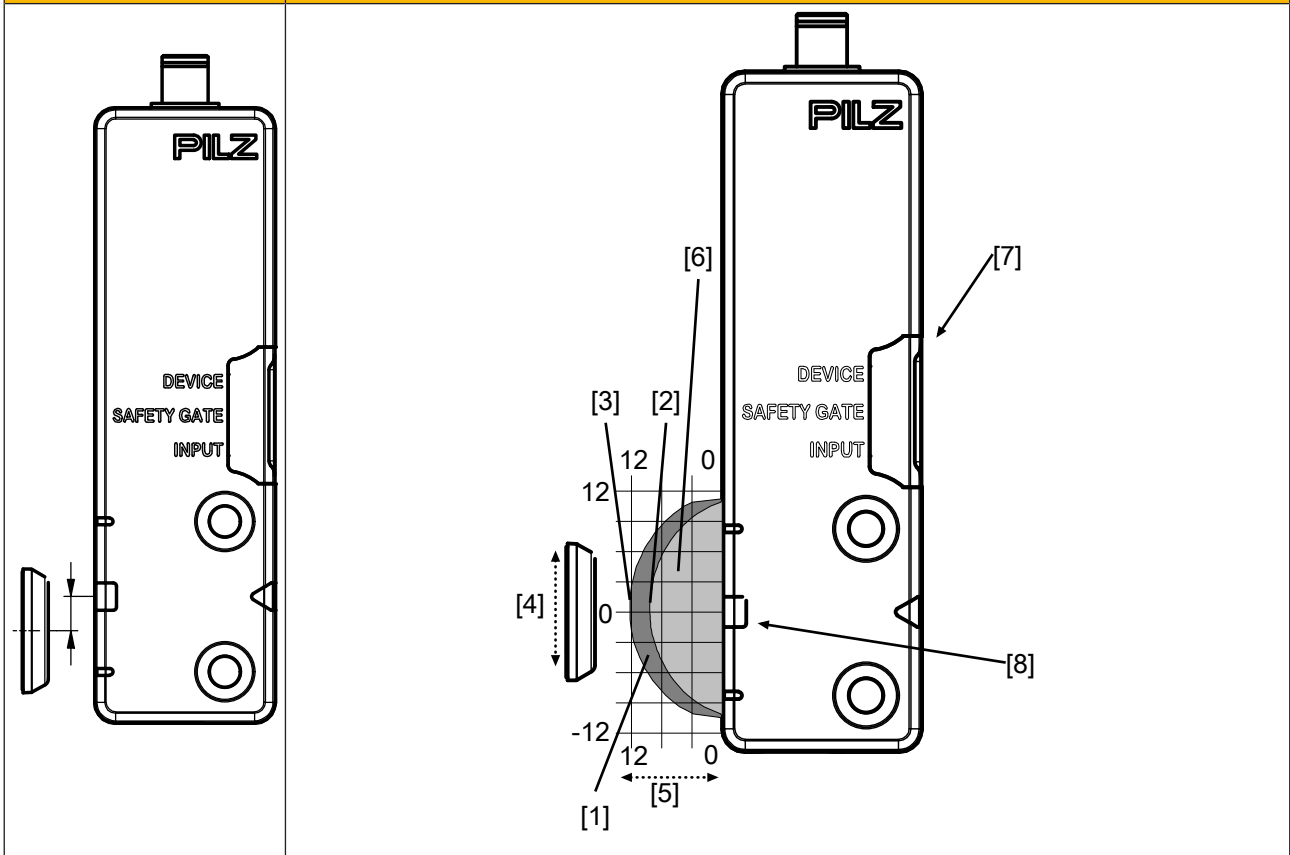

Legend

- [1] Hysteresis
- [2] Typical operating distance S_o
- [3] Typical release distance S_r
- [4] Offset in mm
- [5] Operating distance in mm
- [6] Response range
- [7] Status of LED
- [8] Square marking
- [9] Triangle marking

Vertical offset when aligning to the semicircle marking

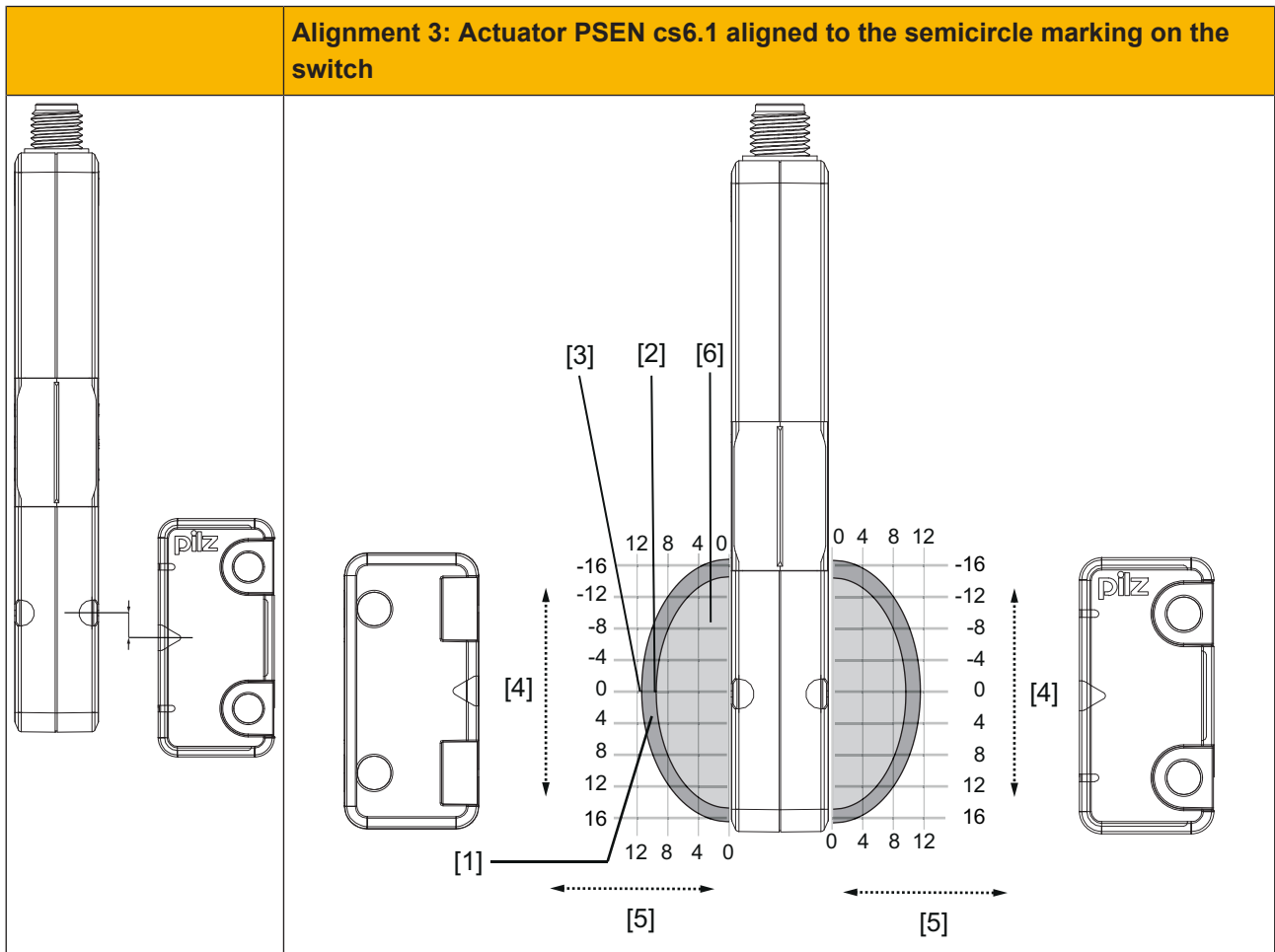

Alignment 3: Actuator PSEN cs6.1 low profile glue or PSEN cs6.1 low profile screw aligned to the semicircle marking on the switch

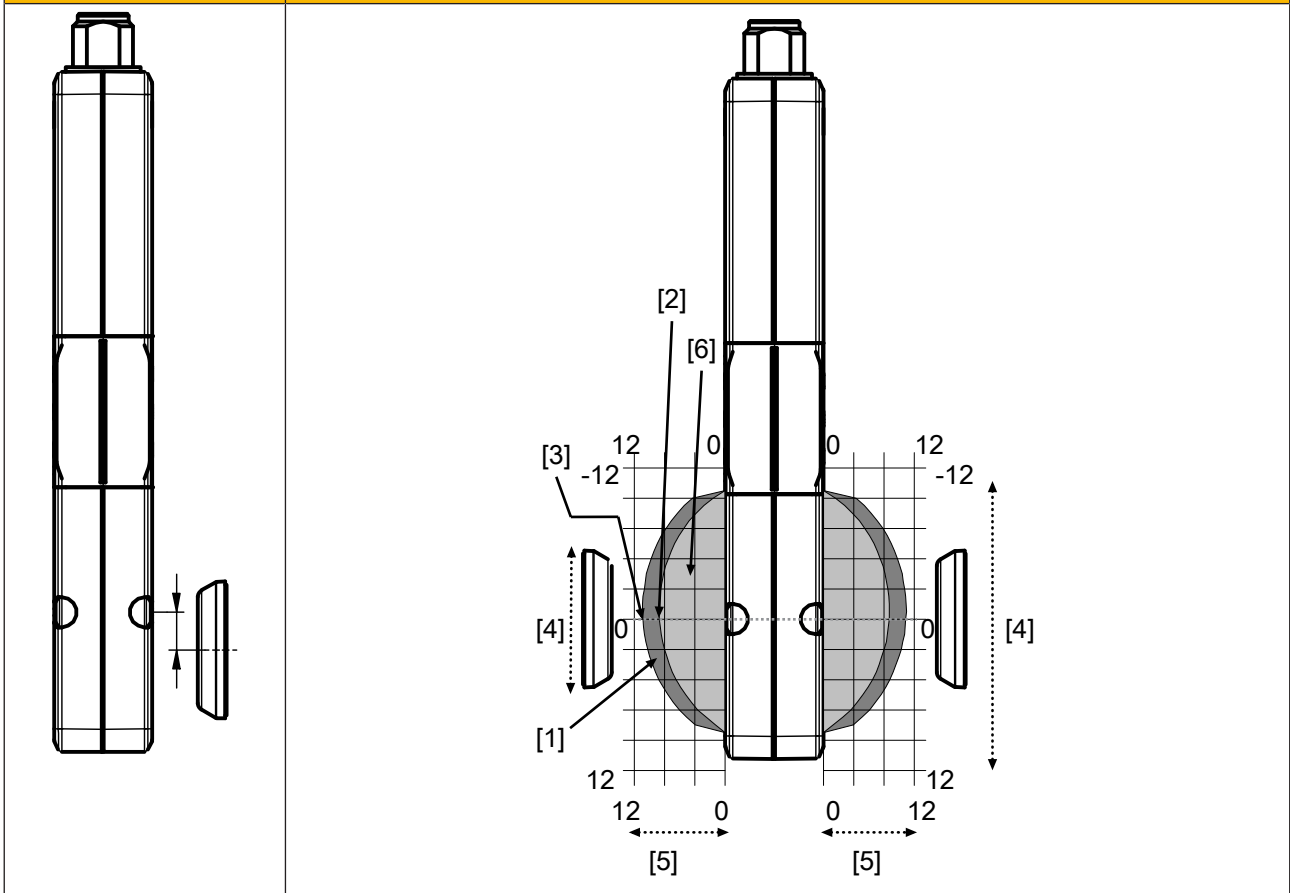

Legend

- [1] Hysteresis
- [2] Typical operating distance S_o
- [3] Typical release distance S_r
- [4] Offset in mm
- [5] Operating distance in mm
- [6] Response range

Wiring

Important information

- ▶ Information given in the [Technical details \[38\]](#) must be followed.
- ▶ Switch off the supply voltage before disconnecting the plug-in connection.
- ▶ Make sure that when connecting or separating the connector the pollution degree 1 or 2 is maintained.
- ▶ The max. cable length I_{\max} in the input circuit is calculated from
 - the max. cable capacitance at the safety outputs (see [Technical data \[38\]](#)).
 - the minimum permitted supply voltage at the safety switch (19.2 V).
- ▶ The power supply must meet the regulations for extra low voltages with protective electrical separation (SELV, PELV).
- ▶ The inputs and outputs of the safety switch must have a protective separation to voltages over 60 VDC.



INFORMATION

Only use safety relays with a 24 VDC supply voltage. Safety relays with a wide-range power supply or in AC device versions have internal potential isolation and are not suitable as evaluation devices.

- ▶ The supply voltage to the safety switch must be protected with a 2 A to 4 A quick-acting fuse.
- ▶ Ensure the wiring and EMC requirements of EN 60204-1 are met.
- ▶ When connecting in series, consider the requirements of manipulation protection and the protection against bypassing or from overriding the safety switch (EN ISO 14119).
- ▶ When the safety inputs of the safety switch are controlled by an upstream device, and they are not wired with 24 V,
 - They must be monitored for shorts across contacts (e.g. by PSEN cs, PSEN ml, PSEN sg or PSEN sl) **or**
 - The faults at the safety inputs that can occur by shorts across contact will have to be excluded by suitable measures (e.g. wiring in accordance with EN 602041).

Pin assignment, connector and cable

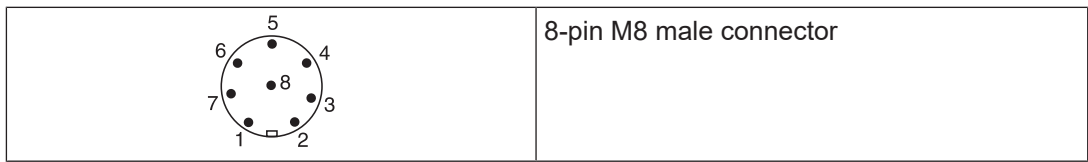

PIN	Connection designation	Function	Wire colour
1	S21	Input, channel 2	white
2	A1	+24 VUB	brown
3	12	Output, channel1	green
4	22	Output, channel2	yellow
5	Y32	Signal output/diagnostic output	grey
6	S11	Input, channel 1	pink
7	A2	0 V UB	blue
8	Y1	Diagnostics input	red

The wire colour also applies for the cable available from Pilz as an accessory.



NOTICE

The inputs S11 and S21 may only be used for the series connection with Pilz sensors.

Connection to evaluation devices

Make sure that the selected evaluation device has the following property:

- ▶ OSSD signals are evaluated through 2 channels with plausibility monitoring

Please note:

- ▶ Information given in the [Technical details \[38\]](#) must be followed.
- ▶ The use of Safety Device Diagnostics is described in the System Description "Safety Device Diagnostics".



CAUTION!

Do not connect the signal output to 0 V!

If the signal output Y32 is connected to 0 V, the safety switch may be damaged as a result. Connect the signal output Y32 to a consumer, e.g. to the input on a control system, or leave the signal output unconnected. Also note the max. current (see [Technical details \[38\]](#)).

Single connection

Connection diagram, single connection without SDD

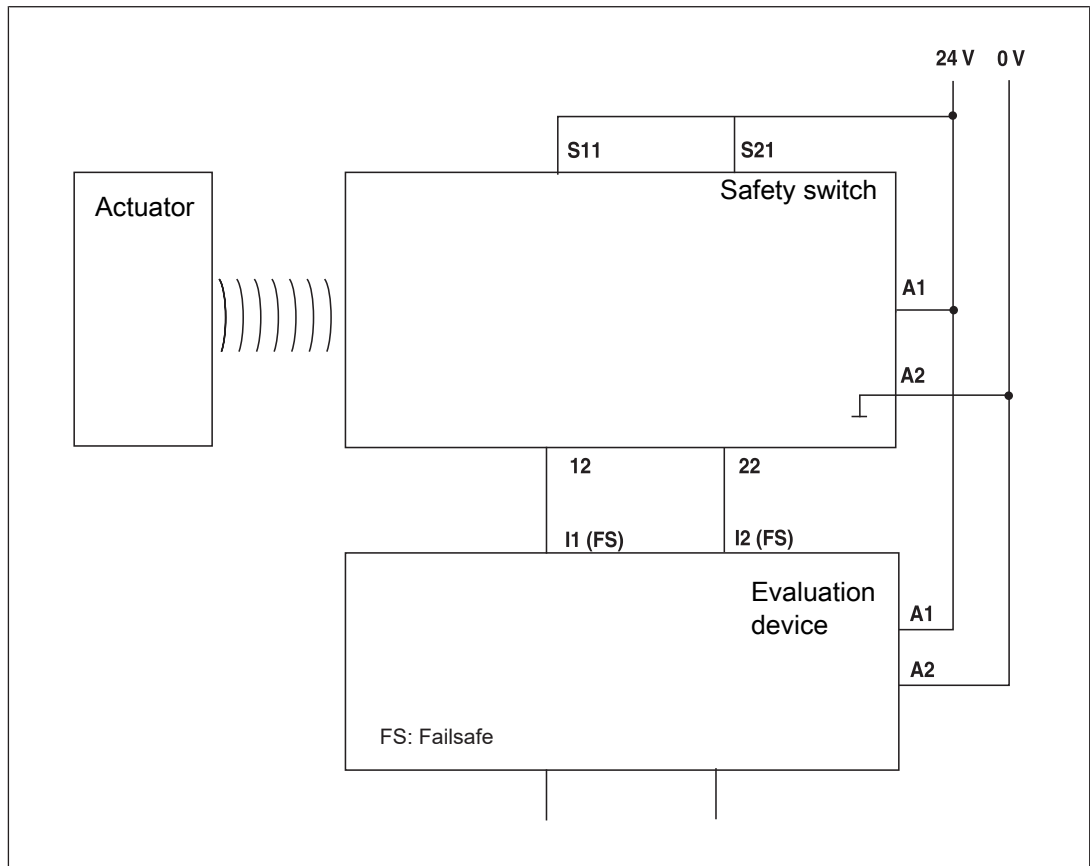

Connection diagram, single connection with SDD

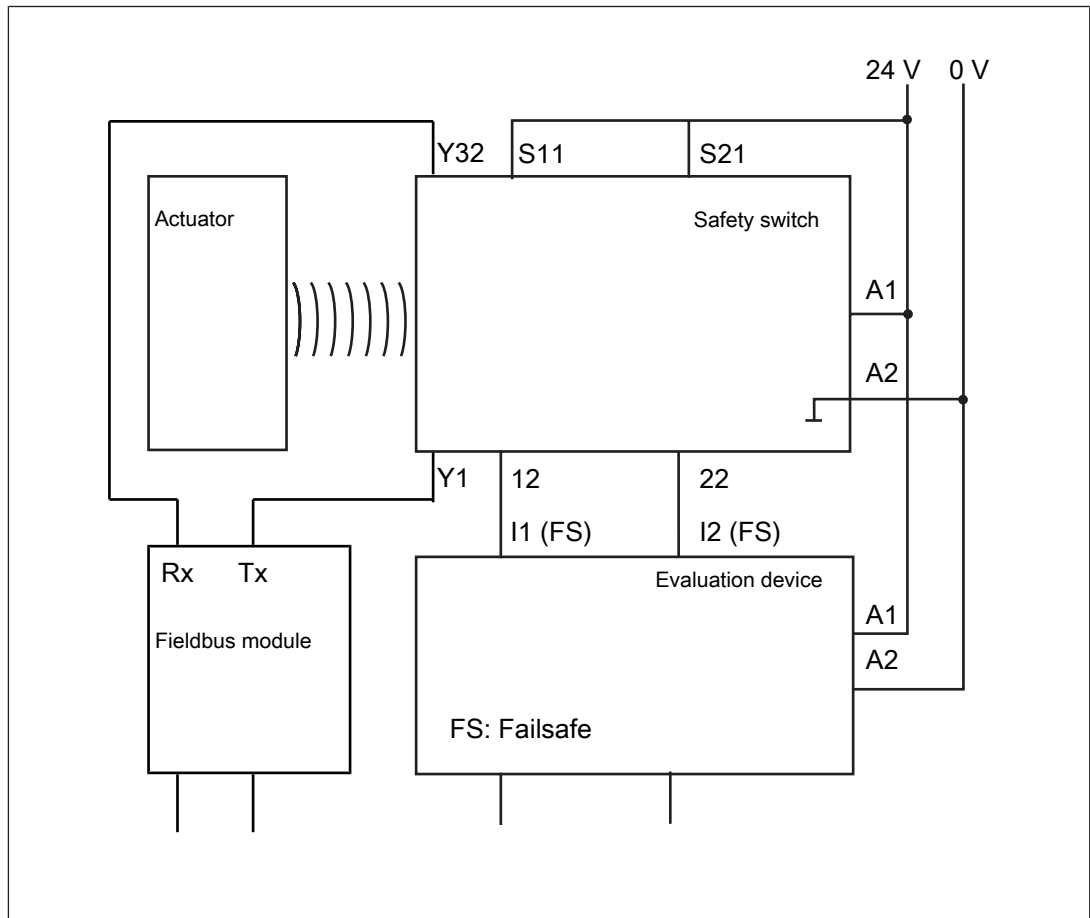

Series connection

The safety sensors PSENcode are also suitable for series connection with other sensors.

The series connection of maximum 32 sensors PSENcs 5.x and PSENcs 6.x is approved for SIL CL 3 without using the SDD.

When using the SDD, the series connection of maximum 16 sensors PSENcs 5.x and PSENcs 6.x is approved

In series connections with use of the SDD, use only use sensors that are suitable for SDD.

In practice, the maximum possible number will be limited by the following parameters, among others:

- ▶ The required SIL level (e.g. SIL CL 3),
- ▶ the required performance level (e.g. PL e (Cat. 4)),
- ▶ the maximum delay or risk time permitted by the application.

Ensure there is sufficient supply voltage, taking inrush currents and fusing into consideration.



CAUTION!

Extension of delay-on de-energisation

When several (n) devices are connected in series, the delay-on de-energisation time adds with the number of interconnected safety switches.

The max. delay-on de-energisation is made up of the risk time (see [Technical details \[38\]](#))

+ (n-1) x max. delay-on de-energisation of the inputs

+ max. delay-on de-energisation of the evaluation device

- ▶ When making series connections using SDD, only use the following passive junctions.
 - PSEN ix2 F4 code
 - PSEN ix2 F8 code
 - PSEN Y junction M8-M12/M12 PIGTAIL
 - PSEN Y junction M8 SENSOR
 - PSEN Y junction M8 cable channel

Connection diagram, series connection without SDD

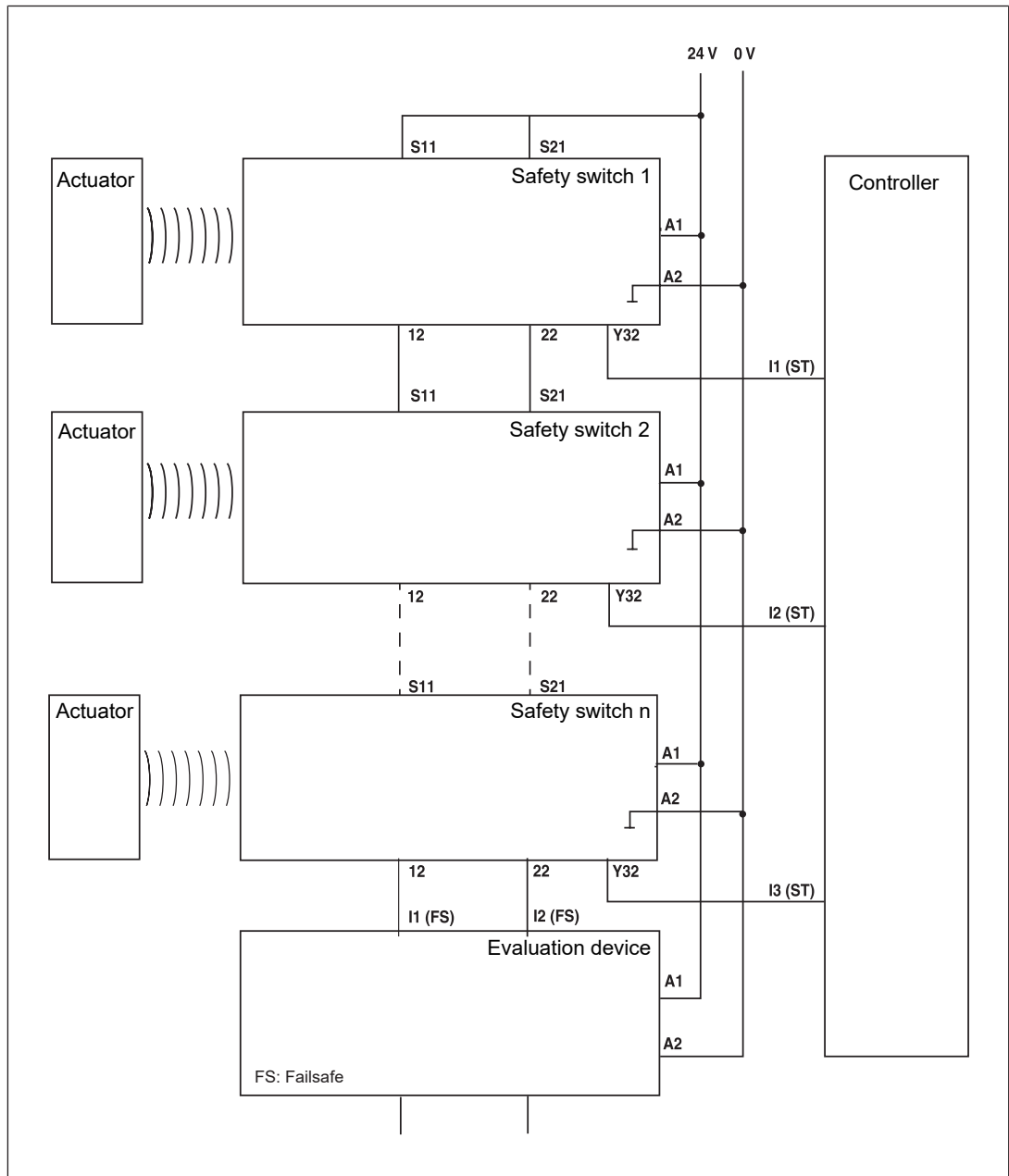

Connection diagram, series connection with SDD

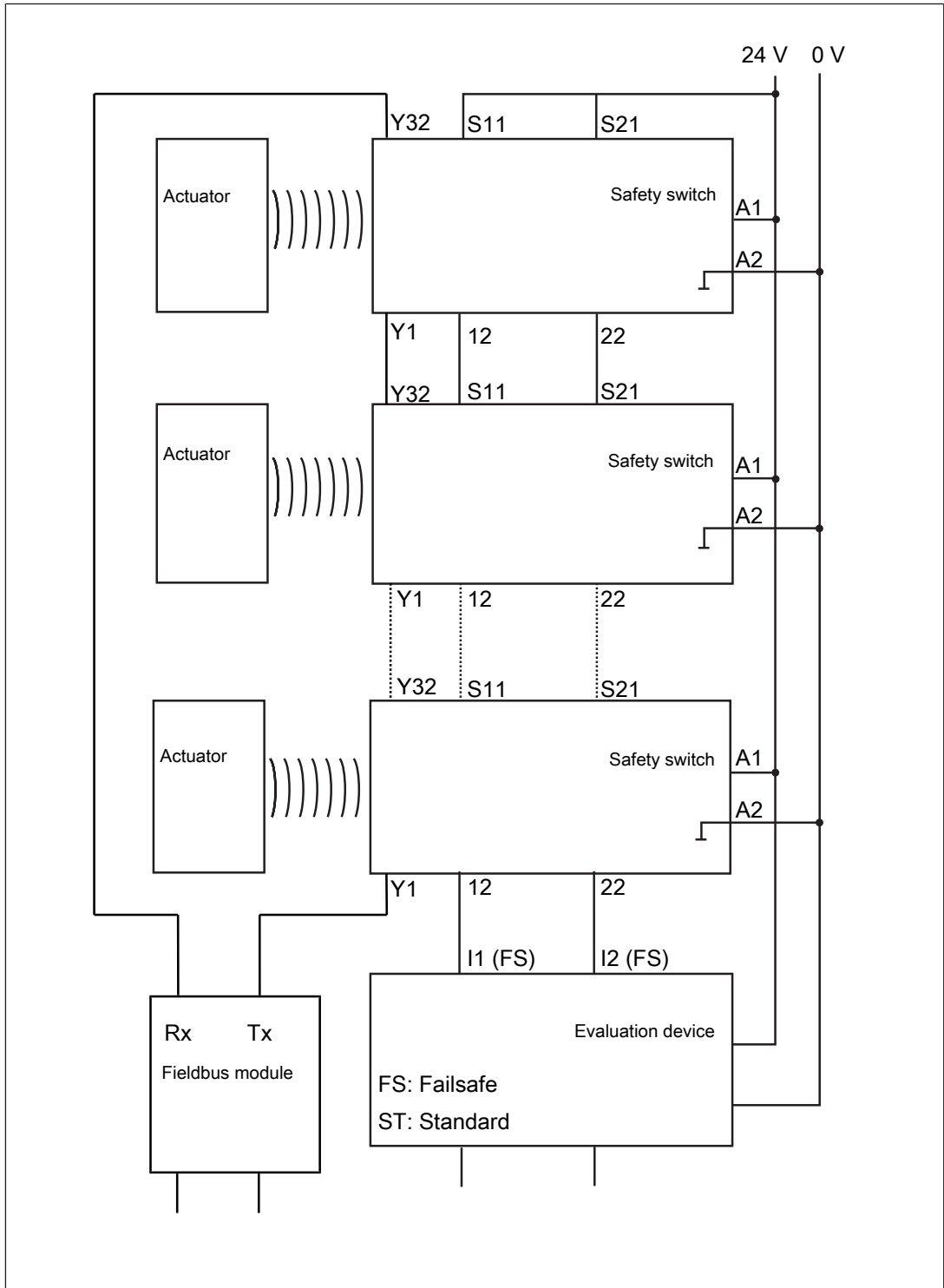

Connection to Pilz evaluation devices

The safety switch PSEN cs6.1p can be connected to Pilz evaluation devices, for example.

Suitable Pilz evaluation devices are, for example:

- ▶ PNOZelog for safety gate monitoring
- ▶ PNOZpower for safety gate monitoring
- ▶ PNOZsigma for safety gate monitoring
- ▶ PNOZ X for safety gate monitoring
- ▶ PNOZmulti for safety gate monitoring
Configure the safety switch in the PNOZmulti Configurator with switch type 3.
- ▶ PSS for safety gate monitoring with standard function block SB064, SB066 or FS_Safety Gate

The correct connection to the respective evaluation device is described in the operating manual for the evaluation device. Make sure that the connection is made in accordance with the specifications in the operating manual for the selected evaluation device.

The connections to two evaluation devices are shown on the following pages, by way of example:

- ▶ PNOZ s3 and
- ▶ PNOZmulti

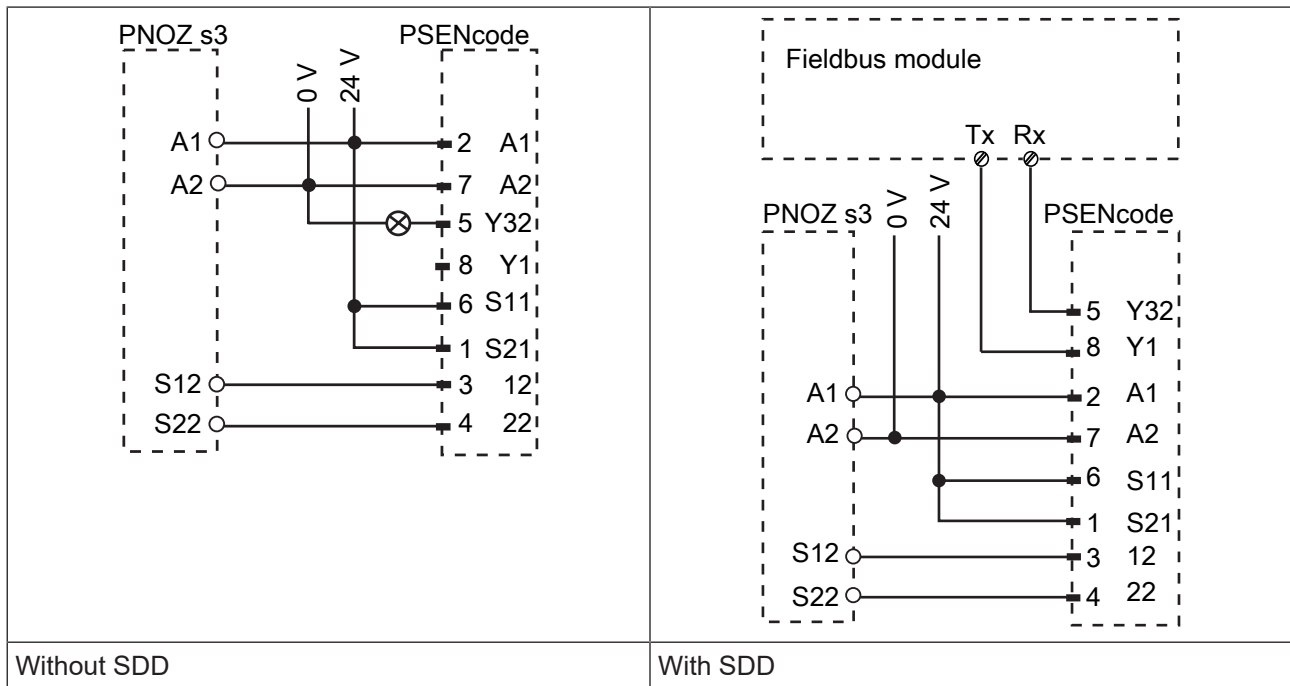

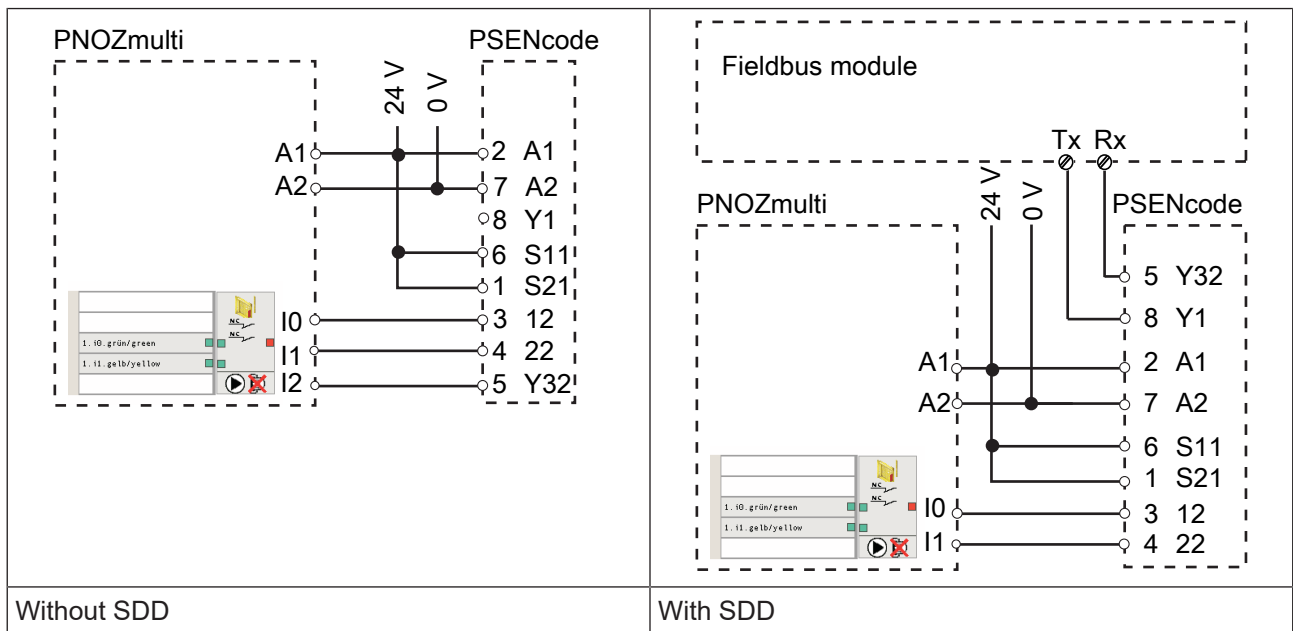

Teaching in the actuator

Teaching in the actuator for the first time:

The first actuator to be detected by the safety switch (see [Intended use \[6\]](#)) is taught in automatically as soon as it is brought into the response range.

To teach in a new actuator:

A maximum of 8 learning procedures are possible.

1. The actuator that is to be taught in must be brought into the safety switch's response range as the only transponder. As soon as the actuator is detected, the "Safety Gate" LED will flash yellow.
2. After 20 s has elapsed, the "Safety Gate" LED turns to quick yellow flashes. Trigger a system reset in the next 120 s by interrupting the power supply.
3. When the supply voltage is switched back on, the learning procedure is complete and the number of permitted additional learning procedures is reduced by 1.



NOTICE

- The actuator must not be removed during the learning procedure.
- It is no longer possible to re-teach this actuator on the same safety switch.

Installation

General



CAUTION!

Potential loss of safety function due to changed device properties

The unit's properties may be affected if installed in an environment containing electrically or magnetically conductive material.

- Please check the operating distances and the assured release distance.

- ▶ The safety switch and actuator should be installed opposite each other in parallel. Make sure that the actuator is aligned to the marking on the safety switch that guarantees the operating distance required by the plant design (see [Operating distances](#) [11]).
- ▶ Torque setting: Please note the information provided under [Technical details](#) [38].
- ▶ The distance between two safety switches must be maintained (see [Technical details](#) [38]).
The distance can be undershot in certain application cases (see diagrams).

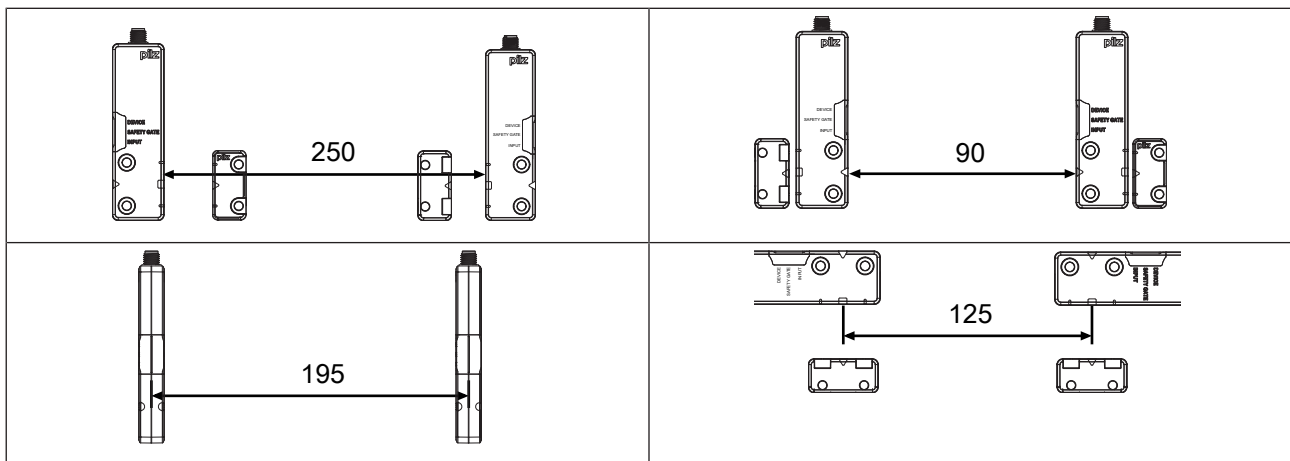

- ▶ Make sure that the safety switch and actuator cannot be used as an end stop.
- ▶ Please note the installation measures in accordance with EN ISO 14119 for a safety switch design 4 and with level of coding High.
- ▶ Please note the permitted bending radii for the cable (see [Technical details](#) [38]), to avoid excessive force on the individual strands.
- ▶ Make sure that the bend protection is not damaged. Such damage can cause the whole product to fail.
- ▶ For simpler installation, the mounting brackets (see [Order reference for Accessories](#) [47]) can be used.



WARNING!

Loss of safety function due to non-permitted enlargement of the assured release distance when using both switching lobes (aligned at semicircle marking)

Depending on the application, serious injury or death may result.

- Install a mechanical stop when using the response range at the semicircle marking, to avoid unintended switching off at the limit of the response range and to prevent the maximum release distance from enlarging impermissibly by using both switching lobes.

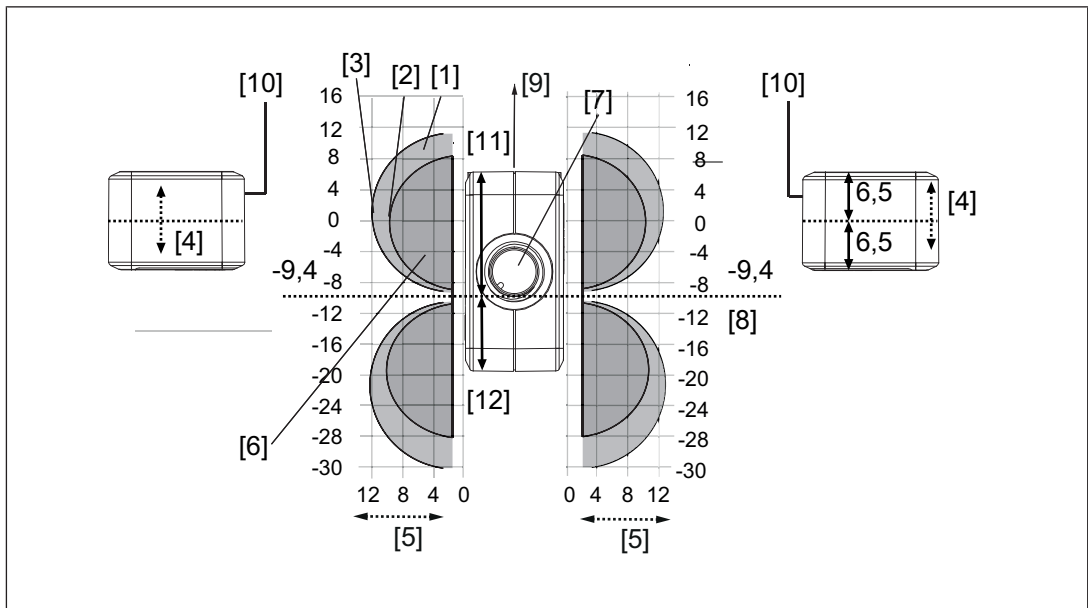

Legend

- [1] Hysteresis
- [2] Typical operating distance S_o
- [3] Typical release distance S_r
- [4] Offset in mm (distance of the middle of the actuator to the zero line in the grid)
- [5] Operating distance in mm
- [6] Response range
- [7] Connector on the safety switch
- [8] Limit of response range, position of gate hinge
- [9] Status of LED
- [10] Sensing face of the actuator, labelled with Pilz logo
- [11] Distance from the front edge of the safety switch to the limit of the response range (position of the gate end stop) = 15.9 mm
- [12] Distance from the rear edge of the safety switch to the limit of the response range (position of the gate end stop) = 10.5 mm

Safety switch

- ▶ Safety switches should only be secured using M4 screws with a flat head (e.g. M4 cheese-head or pan head screws).

Procedure:

1. Provide the mounting surface with two drill holes for fastening the safety switch (see [Dimensions in mm](#)  37).
2. Use a screw to fix the safety switch to the mounting surface.
Make sure that the safety switch marking that is to be used for operation can be operated using the actuator from the right side.
3. Do not fully tighten the second screw on the safety switch.

Actuator 6.1**Procedure actuator PSEN cs6.1**

1. Provide the mounting surface with two drill holes for fastening the actuator (see [Dimensions](#)  37).
2. Use a screw to fix the actuator to the mounting surface.
Make sure that the actuator with the marking (triangle) points towards the marking on the safety switch.
3. Do not fully tighten the second screw on the actuator.

Actuator 6.1 low profile**WARNING!****Loss of the manipulation protection by inadequate environmental conditions**

The loss of the manipulation protection can allow manipulation of the interlocking device and it may lead to serious injury or death.

- Make sure that the actuator has no direct or repetitive contact with materials such as methyl ethyl ketone (MEK), petrol or isopropanol.

- ▶ The actuator is secured against unauthorised removal, and against contamination by the sealing. The seal should be regarded as equivalent to using permanent fastenings in accordance with EN ISO 14119.
- ▶ By removing the actuator, the actuator will be destroyed.
- ▶ The actuator's adhesive force on the materials aluminium, stainless steel, polycarbonate and glass was checked. For deviating surface materials check the adhesive force on the surface.
- ▶ After a cure time of 24 hours, 90 % of the final adhesive force are achieved. The hardening must take place at min. 20 °C. With lower temperatures the cure time is clearly extended.
- ▶ No continuous force must affect the actuator.

Procedure actuator PSEN cs6.1 low profile glue:

1. To seal the low profile actuators correctly, it is necessary to prepare the surface to which the actuator is to be attached.

The surface must be clean, dry and free of grease.

Wipe off any solved grease and contaminations with a new, dry paper cloth.

Clean the surface with 70% isopropanol. Use lint-free paper cloths and change the paper cloths frequently.

The adhesive surface is clean when the paper remains clean.

The cleaned surfaces must be sealed immediately to prevent any new contamination by dust and fingerprints.

2. Remove the protective foil from the assembly aid and fix it flush with the sides (see diagram) to the required sensing area of the safety switch.

3. Only when using the square marking:

Cut off the excess strip on the assembly aid along the perforation (e.g. using a pair of scissors).

4. Place the actuator into the assembly aid so that the actuator's covered adhesive surface is on the surface.

Make sure that the actuator's centre is on the same level as the orientation arrows of the sensor and in the centre of the sensor.

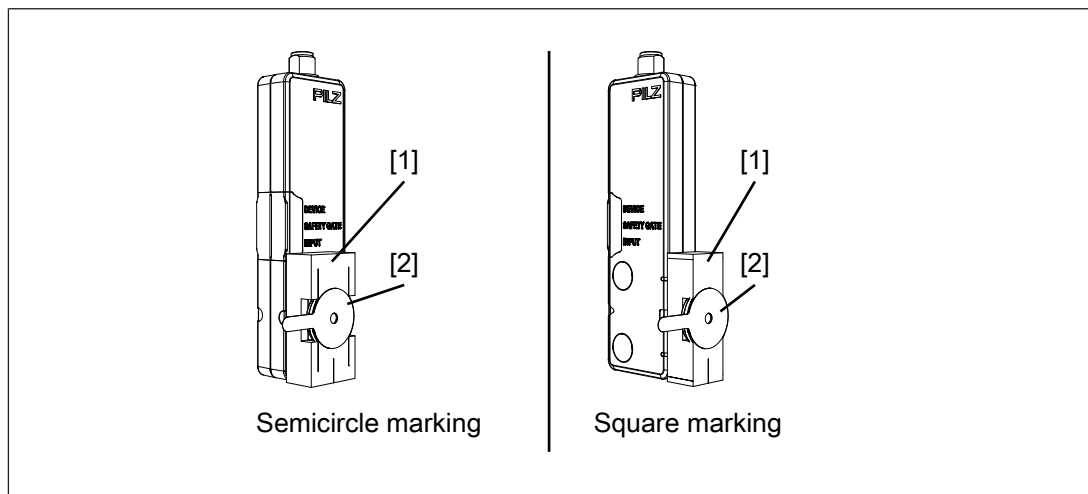

Fig.: Safety switch with assembly aid and low profile actuator oriented to semicircle and square marking

Legend

[1] Assembly aid for low profile actuator

[2] low profile actuator

5. Remove the protective foil from the adhesive foil of the actuator.
Do not touch the adhesive foil after removing the protective foil!
6. Close the safety gate carefully and then press the actuator to the adhesive position.
7. Press on the actuator for at least 3 seconds with approx. 50 N.

After this time, an adhesive force of approx. 50 % is achieved. The full adhesive force is achieved after 72 hours at an ambient temperature of at least 20 °C.

8. Check the adhesive force of the glue after 10 minutes.

The actuator must no move when pressed sideways.

Procedure actuator PSEN cs6.1 low profile screw

1. Provide the mounting surface with a drill hole for an additional screw connection of the actuator (see [Dimensions in mm](#)  37]).

2. To seal the low profile actuators correctly, it is necessary to prepare the surface to which the actuator is to be attached.

The surface must be clean, dry and free of grease.

Wipe off any solved grease and contaminations with a new, dry paper cloth.

Clean the surface with 70% isopropanol. Use lint-free paper cloths and change the paper cloths frequently.

The adhesive surface is clean when the paper remains clean.

The cleaned surfaces must be sealed immediately to prevent any new contamination by dust and fingerprints.

3. Remove the protective foil from the adhesive foil of the actuator.

Do not touch the adhesive foil after removing the protective foil!

4. Insert the screw into the actuator's hole and position the screw at the hole on the mounting surface.

To screw on the actuator, use the supplied plastic M3 countersunk screw.

When using a screw mad from metal the operating distance change, please note the [Warning](#)  28].

5. Then press the actuator firmly to the gluing position.

6. Press on the actuator for at least 3 seconds with approx. 50 N.

After this time, an adhesive force of approx. 50 % is achieved. The full adhesive force is achieved after 72 hours at an ambient temperature of at least 20 °C.

7. Check the adhesive force of the glue after 10 minutes.

The actuator must no move when pressed sideways.

8. Additionally, attach the actuator using the M3 plastic screw supplied.

Align safety switch and actuator

- ▶ The actuator should only be secured using M4 screws with a flat head (e.g. M4 cheese-head or pan head screws).

The actuator should be protected from unauthorised removal and from contamination. Close the mounting holes using the seals provided. The use of seals should be regarded as equivalent to using permanent fastenings in accordance with EN ISO 14119.

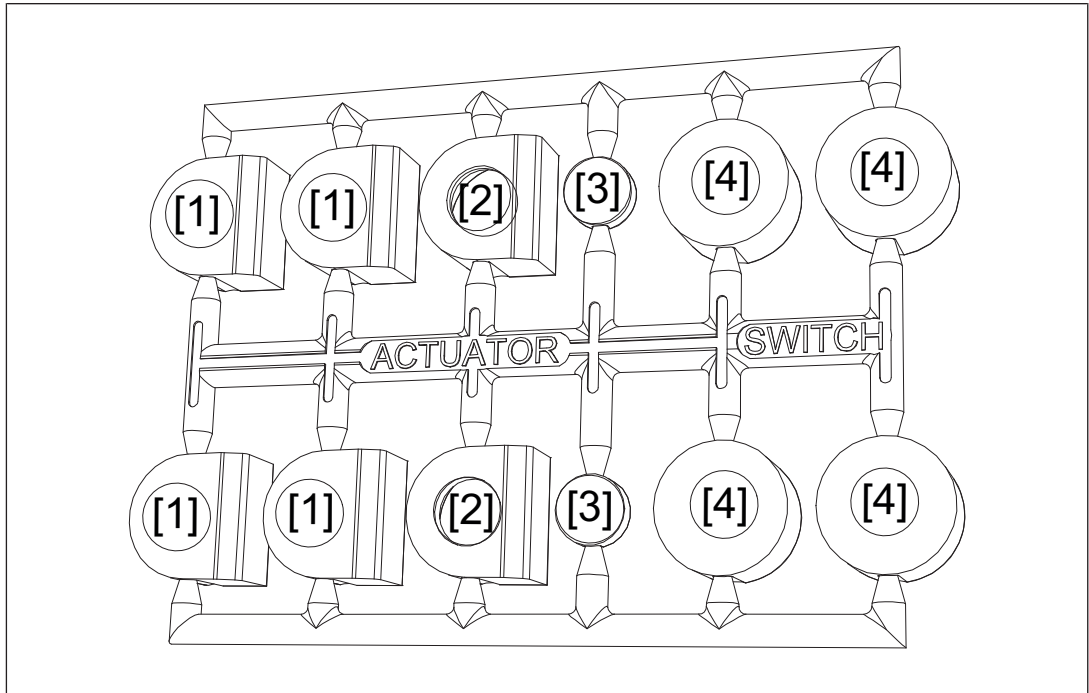

Legend

- [1] 4 seals for actuators
- [2] Unused seals
- [3] 2 seals for actuators
- [4] 2 seals for switches, 2 seals unused

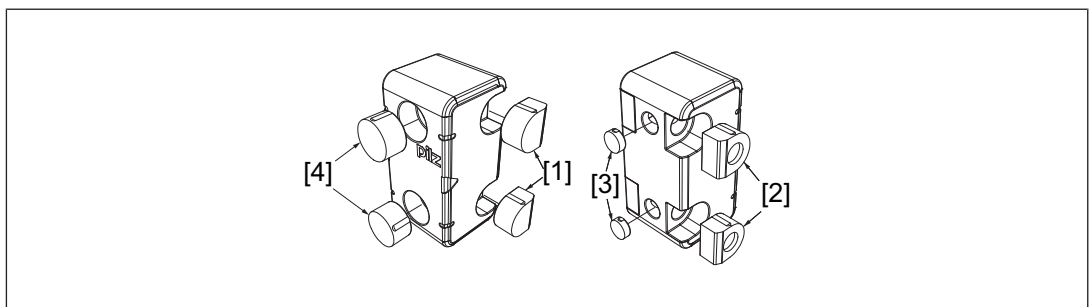

Fig.: Applying the screw covers [1] and [3] on the actuator

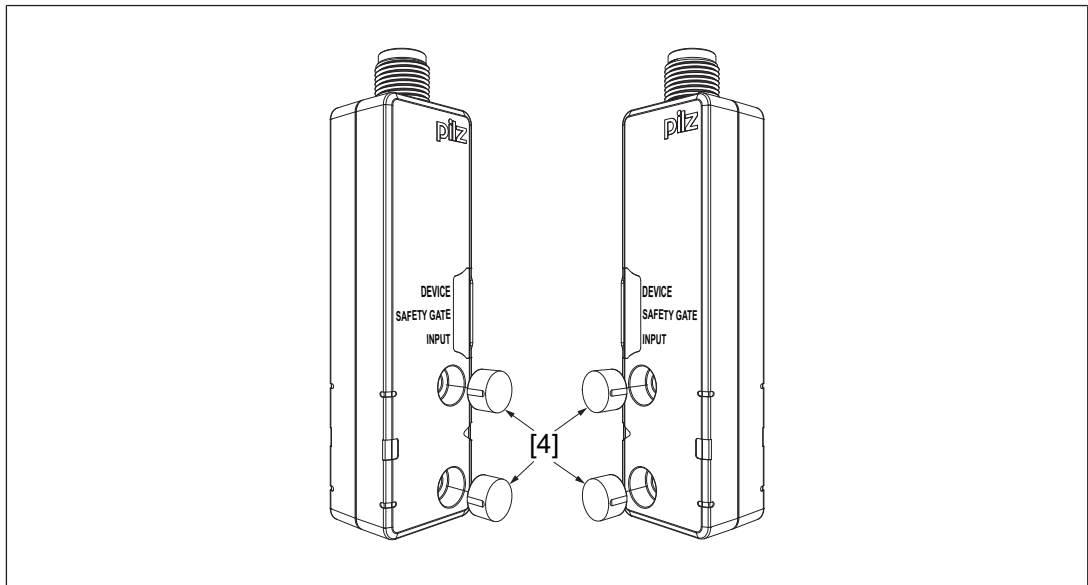

Fig.: Applying the screw cover [4] on the switch

Procedure:

1. Align the safety switch and tighten the screws.
2. Actuator PSEN cs6.1
Align the actuator and tighten the screws.
3. Use the seals to close the mounting holes on the sensing face of the safety switch (see diagram, [4]).

Use in operating heights higher than 2000 m above sea level

When using the PSEN cs6.1p note the reduced max. ambient temperature of +60 °C at a height of 2000 m to 4000 m.

Adjustment

- ▶ The stated operating distances (see [Technical details \[38\]](#)) only apply when the safety switch and actuator are installed facing each other in parallel. Operating distances may deviate if other arrangements are used.
- ▶ Note the maximum permitted lateral and vertical offset (see [Operating distances \[11\]](#) and [Lateral and vertical offset \[13\]](#)).

Operation



NOTICE

The safety function should be checked after initial commissioning and each time the plant/machine is changed. The safety functions may only be checked by qualified personnel.

Status indicators:





Legend:

	LED off
	LED on
	LED flashes (500 ms on, 500 ms off)
	LED flashes quickly (50 ms on, 950 ms off)
	LED flashes very quickly (30 ms on, 470 ms off)













Normal mode

LED status		Switch status
Device	Green	Ready for operation
Safety Gate	yellow	Actuator is within the response range
	Off	Actuator is outside the response range
Input	yellow	Both safety inputs are high
	Off	Both safety inputs are low

LED status, teach-in actuator

LED status			Switch status	Remedy / measure
Device	Safety Gate	Input		
 Green	 yellow	Display not definitive	Teaching actuator. Duration approx. 20 seconds	-
 Green	 yellow	Display not definitive	Actuator teach-in complete.	Switch voltage off and then on again.

Error display

LED status			Switch status	Remedy / measure
Device	Safety Gate	Input		
 Red	 off	 off	Internal error on switch	Change the switch.
 Red	 Yellow	 Yellow	Supply voltage is outside the tolerance range	Ensure the voltage supply corresponds to the Technical details [38] .
 Yellow	Display not definitive	Display not definitive	Supply voltage is at the limit of the tolerance range	Ensure the voltage supply corresponds to the Technical details [38] .
 Red	Display of last status	Display of last status	Outputs in fault condition	Check the outputs and switch the voltage off and then on again.
 Green	 Yellow	Display not definitive	Wrong actuator	Use the actuator that has been taught-in or teach in a new actuator (see Teaching in the actuator [27]).
 off	 Yellow	 Yellow	Switch doesn't start	Change the switch.

Dimensions in mm

Safety switch	
<p>Front view of the safety switch. Dimensions: total height 90 mm, top mounting height 7.6 mm, width 26.4 mm, bottom LED height 7.4 mm, and two circular ports with a 22 mm diameter. Markings [1], [2], and [3] are indicated.</p>	<p>Side view of the safety switch. Dimensions: total height 97.6 mm and width 13 mm. Markings [4] are indicated on the side.</p>
Actuator	
<p>Front view of the actuator. Dimensions: total height 22 mm, width 18 mm, and mounting hole diameter 4.5 mm. Markings [2] and [3] are indicated.</p>	<p>Side view of the actuator. Dimensions: total height 37 mm, width 13 mm, and mounting hole diameter 4.5 mm. Markings [2] and [3] are indicated.</p>

Legend:

- [1] Square marking
- [2] Triangle marking
- [3] LEDs
- [4] Semicircle marking

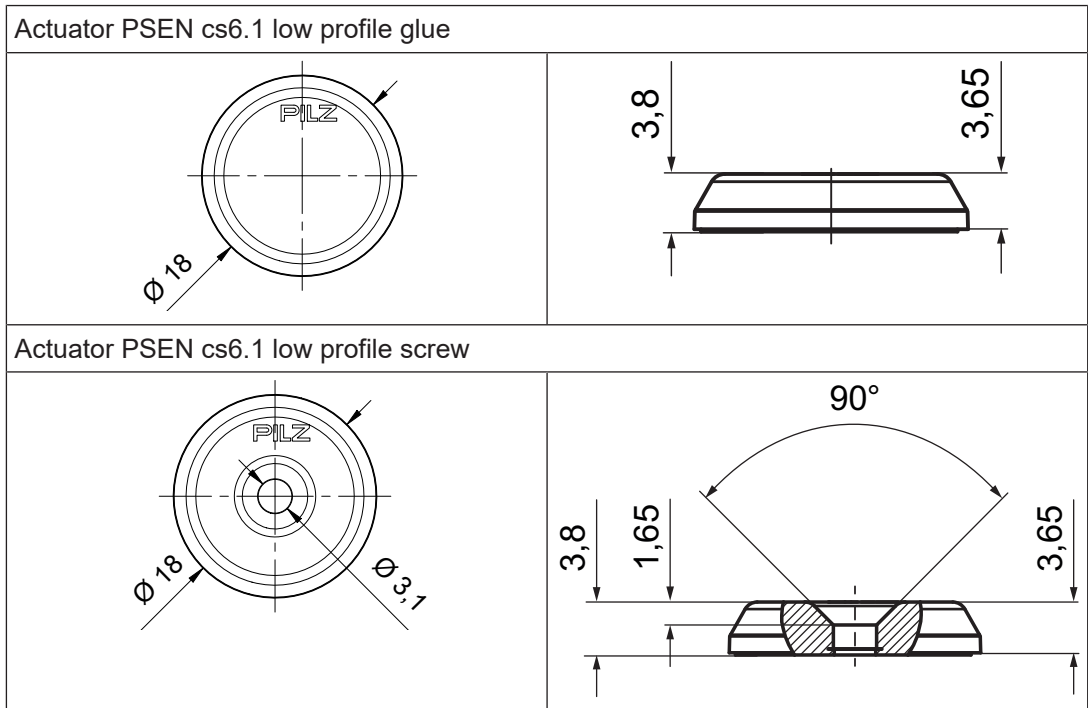

Technical details safety switch

General

Certifications	CE, EAC (Eurasian), ECOLAB, FCC, IC, TÜV, cULus Listed
Sensor's mode of operation	Transponder
Coding level in accordance with EN ISO 14119	High
Design in accordance with EN ISO 14119	4
Classification in accordance with EN 60947-5-3	PDDb
Pilz coding type	fully coded

Transponder

Frequency band	122 kHz - 128 kHz
Max. transmitter output	15 mW

Electrical data

Supply voltage	
Voltage	24 V
Kind	DC
Voltage tolerance	-20 %/+20 %
Output of external power supply (DC)	1 W
Max. switching frequency	3 Hz
Max. cable capacitance at the safety outputs	
No-load, PNOZ with relay contacts	40 nF
PNOZmulti, PNOZelog, PSS	40 nF
Max. inrush current impulse	
Current pulse, A1	0,5 A
No-load current	25 mA

Inputs	
Number	2
Voltage at inputs	24 V DC
Input current range	1,6 - 3 mA
Semiconductor outputs	
OSSD safety outputs	2
Signal outputs	1
Switching current per output	100 mA
Breaking capacity per output	2,4 W
Potential isolation from system voltage	No
Short circuit-proof	yes
Residual current at outputs	400 µA
Voltage drop at OSSDs	1 V
Conditional rated short circuit current	100 A
Lowest operating current	2 mA
Utilisation category in accordance with EN 60947-1	DC-12
Times	
Test pulse duration, safety outputs	150 µs
Switch-on delay	
after UB is applied	1 s
Inputs typ.	1 ms
Inputs max.	3 ms
Actuator typ.	30 ms
Actuator max.	50 ms
Delay-on de-energisation	
Inputs typ.	2 ms
Inputs max.	4 ms
Actuator typ.	30 ms
Actuator max.	40 ms
Risk time in accordance with EN 60947-5-3	150 ms
Supply interruption before de-energisation	20 ms
Simultaneity, channel 1 and 2 max.	∞
Environmental data	
Ambient temperature	
In accordance with the standard	EN 60068-2-14
Temperature range	-25 - 70 °C
Max. at max. operating height	+60 °C
Max. at max. operating height <2000 m	+70 °C
Storage temperature	
In accordance with the standard	EN 60068-2-1/-2
Temperature range	-40 - 85 °C
Climatic suitability	
In accordance with the standard	EN 60068-2-30
Humidity	93 % r. h. at 40 °C
Max. operating height above sea level	4000 m

Environmental data

EMC	EN 60947-5-3
Vibration	
In accordance with the standard	EN 60947-5-2
Frequency	10 - 55 Hz
Amplitude	1 mm
Shock stress	
In accordance with the standard	EN 60947-5-2
Acceleration	30g
Duration	11 ms
Airgap creepage	
Overvoltage category	III
Pollution degree	3
Rated insulation voltage	75 V
Rated impulse withstand voltage	1 kV
Protection type	
Housing	IP66, IP67

Operating distances

Actuator 1	
Type	PSEN cs6.1
Repetition accuracy switching distances	3 %
Change of operating distance with temperature changes	+0,02mm/°C
Actuator 2	
Type	PSEN cs6.1 low profile glue
Repetition accuracy switching distances	3 %
Change of operating distance with temperature changes	+0,02mm/°C
Actuator 3	
Type	PSEN cs6.1 low profile screw
Repetition accuracy switching distances	3 %
Change of operating distance with temperature changes	+0,02mm/°C

Operating distances when the actuator approaches square marking

Actuator 1	
Type	PSEN cs6.1
Assured operating distance Sao	8 mm
Assured release distance Sar	20 mm
Typical operating distance So	11 mm
Typical release distance Sr	14 mm
Typical hysteresis	2 mm

Operating distances when the actuator approaches square marking

Actuator 2

Type	PSEN cs6.1 low profile glue
Assured operating distance S_{ao}	5 mm
Assured release distance S_{ar}	20 mm
Typical operating distance S_o	10 mm
Typical release distance S_r	12 mm
Typical hysteresis	2 mm

Actuator 3

Type	PSEN cs6.1 low profile screw
Assured operating distance S_{ao}	5 mm
Assured release distance S_{ar}	20 mm
Typical operating distance S_o	10 mm
Typical release distance S_r	12 mm
Typical hysteresis	2 mm

Operating distances when the actuator approaches triangle marking

Actuator 1

Type	PSEN cs6.1
Assured operating distance S_{ao}	4 mm
Assured release distance S_{ar}	12 mm
Typical operating distance S_o	5 mm
Typical release distance S_r	8 mm
Typical hysteresis	2 mm

Operating distances when the actuator approaches semicircle marking

Actuator 1

Type	PSEN cs6.1
Assured operating distance S_{ao}	6 mm
Assured release distance S_{ar}	19 mm
Typical operating distance S_o	9 mm
Typical release distance S_r	11 mm
Typical hysteresis	2 mm

Actuator 2

Type	PSEN cs6.1 low profile glue
Assured operating distance S_{ao}	5 mm
Assured release distance S_{ar}	17 mm
Typical operating distance S_o	8 mm
Typical release distance S_r	10 mm
Typical hysteresis	2 mm

Operating distances when the actuator approaches semicircle marking

Actuator 3

Type	PSEN cs6.1 low profile screw
Assured operating distance S_{ao}	5 mm
Assured release distance S_{ar}	17 mm
Typical operating distance S_o	8 mm
Typical release distance S_r	10 mm
Typical hysteresis	2 mm

Mechanical data

Min. distance between safety switches	250 mm
Sensor flush installation in accordance with EN 60947-5-2	Yes, follow installation guidelines
Connection type	M8, 8-pin male connector
Material	PA+GF, PBT, polycarbonate
Max. torque setting for fixing screws	1 Nm
Dimensions	
Height	26,4 mm
Width	97,6 mm
Depth	13 mm
Weight	48 g

Where standards are undated, the 2015-11 latest editions shall apply.

Technical details actuator

Order no. 542180 PSEN cs6.1

See below for more order numbers

General

Certifications	CE, EAC (Eurasian), ECOLAB, TÜV, cULus Listed
Sensor's mode of operation	Transponder
Coding level in accordance with EN ISO 14119	High
Pilz coding type	fully coded

Transponder

Frequency band	122 kHz - 128 kHz
----------------	--------------------------

Environmental data

Ambient temperature

In accordance with the standard	EN 60068-2-14
Temperature range	-25 - 70 °C
Max. at max. operating height	+60 °C
Max. at max. operating height <2000 m	+70 °C

Storage temperature

In accordance with the standard	EN 60068-2-1/-2
Temperature range	-40 - 85 °C

Environmental data

Climatic suitability

In accordance with the standard	EN 60068-2-30
Humidity	93 % r. h. at 40 °C

Max. operating height above sea level	4000 m
---------------------------------------	---------------

EMC	EN 60947-5-3
-----	---------------------

Vibration

In accordance with the standard	EN 60947-5-2
Frequency	10 - 55 Hz
Amplitude	1 mm

Shock stress

In accordance with the standard	EN 60947-5-2
Acceleration	30g
Duration	11 ms

Protection type

Housing	IP66, IP67
---------	-------------------

Mechanical data

Material	PBT
----------	------------

Max. torque setting for fixing screws	1 Nm
---------------------------------------	-------------

Dimensions

Height	18 mm
Width	37 mm
Depth	13 mm

Weight	10 g
--------	-------------

Order no. 542187 PSEN cs6.1 low profile glue

Order no. 542188 PSEN cs6.1 low profile screw

General	542187	542188
Certifications	CE, EAC (Eurasian), TÜV, cULus Listed	CE, EAC (Eurasian), TÜV, cULus Listed
Sensor's mode of operation	Transponder	Transponder
Coding level in accordance with EN ISO 14119	High	High
Pilz coding type	fully coded	fully coded
Transponder	542187	542188
Frequency band	122 kHz - 128 kHz	122 kHz - 128 kHz
Environmental data	542187	542188
Ambient temperature		
In accordance with the standard	EN 60068-2-14	EN 60068-2-14
Temperature range	-25 - 70 °C	-25 - 70 °C
Max. at max. operating height	+60 °C	+60 °C
Max. at max. operating height <2000 m	+70 °C	+70 °C

Environmental data		
	542187	542188
Storage temperature		
In accordance with the standard	EN 60068-2-1/-2	EN 60068-2-1/-2
Temperature range	-40 - 85 °C	-40 - 85 °C
Climatic suitability		
In accordance with the standard	EN 60068-2-30	EN 60068-2-30
Humidity	93 % r. h. at 40 °C	93 % r. h. at 40 °C
Max. operating height above sea level		
	4000 m	4000 m
EMC		
	EN 60947-5-3	EN 60947-5-3
Vibration		
In accordance with the standard	EN 60947-5-2	EN 60947-5-2
Frequency	10 - 55 Hz	10 - 55 Hz
Amplitude	1 mm	1 mm
Shock stress		
In accordance with the standard	EN 60947-5-2	EN 60947-5-2
Acceleration	30g	30g
Duration	11 ms	11 ms
Protection type		
Housing	IP67	IP67
Mechanical data		
	542187	542188
Material		
Top	PBT	PBT
Max. torque setting for fixing screws		
	–	0,1 Nm
Dimensions		
Height	3,8 mm	3,8 mm
Width	18 mm	18 mm
Depth	18 mm	18 mm
Weight		
	2 g	2 g

Where standards are undated, the 2015-11 latest editions shall apply.

Classification according to ZVEI, CB24I

The following tables describe the classes and specific values of the product interface and the classes of interfaces compatible with it. The classification is described in the ZVEI position paper "Classification of Binary 24 V Interfaces - Functional Safety aspects covered by dynamic testing".

Input

Interfaces

Drain	
Class	C2

Source	
Class	C2, C3

Drain parameters

Test pulse duration, safety outputs	450 µs
Min. test pulse interval	1,25 ms
Min. input resistance	9,9 kOhm
Max. capacitive load	1 nF

Single-pole output

Interfaces

Source	
Interface	Sensor
Class	C2

Drain	
Class	C1, C2

Source parameters

Max. test pulse duration	150 µs
Max. rated current	0,1 A
Max. capacitive load	40 nF

Safety characteristic data



NOTICE

You must comply with the safety characteristic data in order to achieve the required safety level for your plant/machine.

Operating mode	EN ISO 13849-1: 2015 PL	EN ISO 13849-1: 2015 Category	EN 62061 SIL CL	EN 62061 PFH _D [1/h]	IEC 61511 SIL	IEC 61511 PFD	EN ISO 13849-1: 2015 T _M [year]
2-ch. OSSD	PL e	Cat. 4	SIL CL 3	9,56E-10	–	8,51E-06	20

Explanatory notes for the safety-related characteristic data:

- ▶ The SIL CL value in accordance with EN 62061 corresponds to the SIL value in accordance with EN 61508.
- ▶ T_M is the maximum mission time in accordance with EN ISO 13849-1. The value also applies as the retest interval in accordance with EN 61508-6 and IEC 61511 and as the proof test interval and mission time in accordance with EN 62061.

All the units used within a safety function must be considered when calculating the safety characteristic data.



INFORMATION

A safety function's SIL/PL values are **not** identical to the SIL/PL values of the units that are used and may be different. We recommend that you use the PAscal software tool to calculate the safety function's SIL/PL values.

Supplementary data

Radio approval

USA/Canada

FC FCC ID: VT8-PSENC55
IC: 7482A-PSENC55

FCC/IC-Requirements:
 This product complies with Part 15 of the FCC Rules and with Industry Canada licence-exempt RSS standards. Operation is subject to the following two conditions:
 1) this product may not cause harmful interference, and
 2) this product must accept any interference received, including interference that may cause undesired operation.

Changes or modifications made to this product not expressly approved by Pilz may void the FCC authorization to operate this equipment.

NOTE: This equipment has been tested and found to comply with the limits for a Class A digital device, pursuant to Part 15 of the FCC Rules. These limits are designed to provide reasonable protection against harmful interference when the equipment is operated in a commercial environment. This equipment generates, uses, and can radiate radio frequency energy and, if not installed and used in accordance with the instruction manual, may cause harmful interference to radio communications. Operation of this equipment in a residential area is likely to cause harmful interference in which case the user will be required to correct the interference at his own expense.

Le présent produit est conforme aux CNR d'Industrie Canada applicables aux appareils radio exempts de licence. L'exploitation est autorisée aux deux conditions suivantes:
 (1) le produit ne doit pas produire de brouillage, et
 (2) l'utilisateur de le produit doit accepter tout brouillage radioélectrique subi, même si le brouillage est susceptible d'en compromettre le fonctionnement.

Order reference

Safety switch

Product type	Features		Order no.
PSEN cs6.1p 1switch	Safety switch, fully coded	8-pin M8 male connector	542 150

Actuator

Product type	Features		Order no.
PSEN cs6.1 1 actuator	Actuator, fully coded		542 180
PSEN cs6.1 low profile glue 1 actuator	Actuator, fully coded For the gluing as a permanent fastening incl. assembly aid made of foam		542 187
PSEN cs6.1 low profile screw 1 actuator	Actuator, fully coded For gluing as a permanent fastening optional: Additional screw connection using M3 plastic screw incl. assembly aid made of foam		542 188

Complete systems

Product type	Features		Order no.
PSEN cs6.1p/PSEN cs6.1 1 unit	Safety gate system, fully coded	8-pin M8 male connector	542 100

Accessories**Accessories for installation**

Product type	Features		Order no.
PSEN cs bracket stop swinging door	Assembly guide for PSEN cs 5.x and 6.x on strut profile (2x) for swinging door		532 108
PSEN cs bracket stop sliding door	Assembly guide for PSEN cs 5.x and 6.x on strut profile (2x) for sliding door		532 109
PSEN bracket	Mounting bracket		532 110
PSEN mag/cs bracket straight	Mounting plate for strut profile (2x)		532 111
PSEN screw M4x12 10pcs	Safety screws made from stainless steel with one-way slot		540 309
PSEN screw M4x16 10pcs	Safety screws made from stainless steel with one-way slot		540 310

Cable

Product type	Connection 1	Connection 2	Length	Order no.	
PSEN cable M8-8sf, 2m	Straight, M8, 8-pin, socket	Open cable	2 m	533 150	
PSEN cable M8-8sf, 5m			5 m	533 151	
PSEN cable M8-8sf, 10m			10 m	533 152	
PSEN cable M8-8af, 10m			Angled, M8, 8-pin, socket	10 m	533 162
PSEN cable M8-8sf, 20m			Straight, M8, 8-pin, socket	20 m	533 153
PSEN cable M8-8sf, 30m				30 m	533 154
PSEN cable M8-8sf M8-sm	Straight, M8, 8-pin, pin	Straight, M8, 8-pin, socket	0.5 m	533 155	
PSEN cable M8-8sf M8-8sm			1 m	533 156	
PSEN cable M8-8sf M8-8sm			2 m	533 157	

Accessories for series connection

Product type	Connection X1	Connection X2	Connection X3	Order no.
PSEN Y junction M8 SENSOR	M8, 8-pin, pin	M8, 8-pin, socket	M8, 8-pin, socket	540 317
PSEN Y junction M8 cable channel	M8, 8-pin, pin	M8, 8-pin, socket	M8, 8-pin, socket	540 318
PSEN Y junction M8-M12/ M12 PIGTAIL	M12, 8-pin, socket	M12, 8-pin, pin	M8, 8-pin, socket	540 337
PSEN converter M8-8sf -- M12-8sm	M12, 8-pin, pin	M8, 8-pin, socket	-	540 329
PDP67 F 4 code	Decentralised passive junction			773 603
PDP67 F 4 code VA	Decentralised passive junction, V2A ring nut			773 613

Accessories for Safety Device Diagnostics

Product type	Features	Connection type	Order no.
PSEN ix2 F4 code	Interface for connecting max. 4 PSEN safety sensors	Spring-loaded terminal	535 111
PSEN ix2 F8 code	Interface for connecting max. 8 PSEN safety sensors	Spring-loaded terminal	535 112
SDD ES ETH	Fieldbus module Modbus/TCP for Safety Device Diagnostics	Spring-loaded terminal	540 130
SDD ES Profibus	Fieldbus module Profibus for Safety Device Diagnostics	Spring-loaded terminal	540 132
SDD ES Profinet	Fieldbus module for Safety Device Diagnostics	Spring-loaded terminal	540 138

EC declaration of conformity

This product/these products meet the requirements of the following directives of the European Parliament and of the Council.

- ▶ 2006/42/EC on machines
- ▶ 2014/53/EC on radio equipment

The complete EC Declaration of Conformity is available on the Internet at www.pilz.com/downloads.

Representative: Norbert Fröhlich, Pilz GmbH & Co. KG, Felix-Wankel-Str. 2, 73760 Ostfildern, Germany